



**weatherchem**

# WEATHERCHEM CORPORATION

*Innovative Packaging Solutions*

2222 Highland Road P.O. Box 1150 Twinsburg, Ohio 44087-1150  
Phone No. (330) 425-4206 Fax No. (330) 425-4586

70mm-400 Finish Flapper  
OUTSIDE HOOK

MATERIAL: POLYPROPYLENE

BOTTLE FINISH: 400  
FITS MOST C.M.A. BOTTLE  
FINISHES

TORQUE RECOMMENDATION:  
28-50 IN.-LBS. THIS REQUIREMENT  
MAY VARY DEPENDING UPON  
BOTTLE MATERIAL, NECK FINISH,  
AND CAPPING EQUIPMENT.

IMPORTANT: WEATHERCHEM  
CLOSURES GENERALLY FOLLOW  
DIMENSIONS WHICH ARE  
COMPATIBLE WITH COMMONLY  
USED C.M.A. SPECIFICATIONS.

S.P.I. OR G.B.I. STANDARD  
BOTTLE FINISHES.

THE CLOSURE DIMENSIONS  
SHOWN ARE THOSE WHICH  
HAVE GENERALLY BEEN FOUND  
TO BE FUNCTIONAL BASED ON  
INDUSTRY EXPERIENCE.  
BECAUSE OF VARIABILITY IN  
GLASS AND PLASTIC CONTAINER  
FINISHES, EACH  
CLOSURE/FINISH SYSTEM  
SHOULD BE INDIVIDUALLY  
EVALUATED AND TESTED TO  
ENSURE IT MEETS APPLICABLE  
PERFORMANCE CRITERIA. SEE  
QUALITY ASSURANCE  
SPECIFICATIONS FOR  
ADDITIONAL INFORMATION.

WEATHERCHEM RESERVES THE  
RIGHT TO REVISE ANY OR ALL  
SPECIFICATIONS AND  
REQUIREMENTS.

SHT. 1 OF 1  
DATE: 19-Nov-2010  
DRAWN BY: ADC

AUTHORIZED FOR USE BY:

**Amber Carlile**

DATE

**Jan 17, 2011**

70mm-400 GC  
Special "H"

**S-196-01-01**

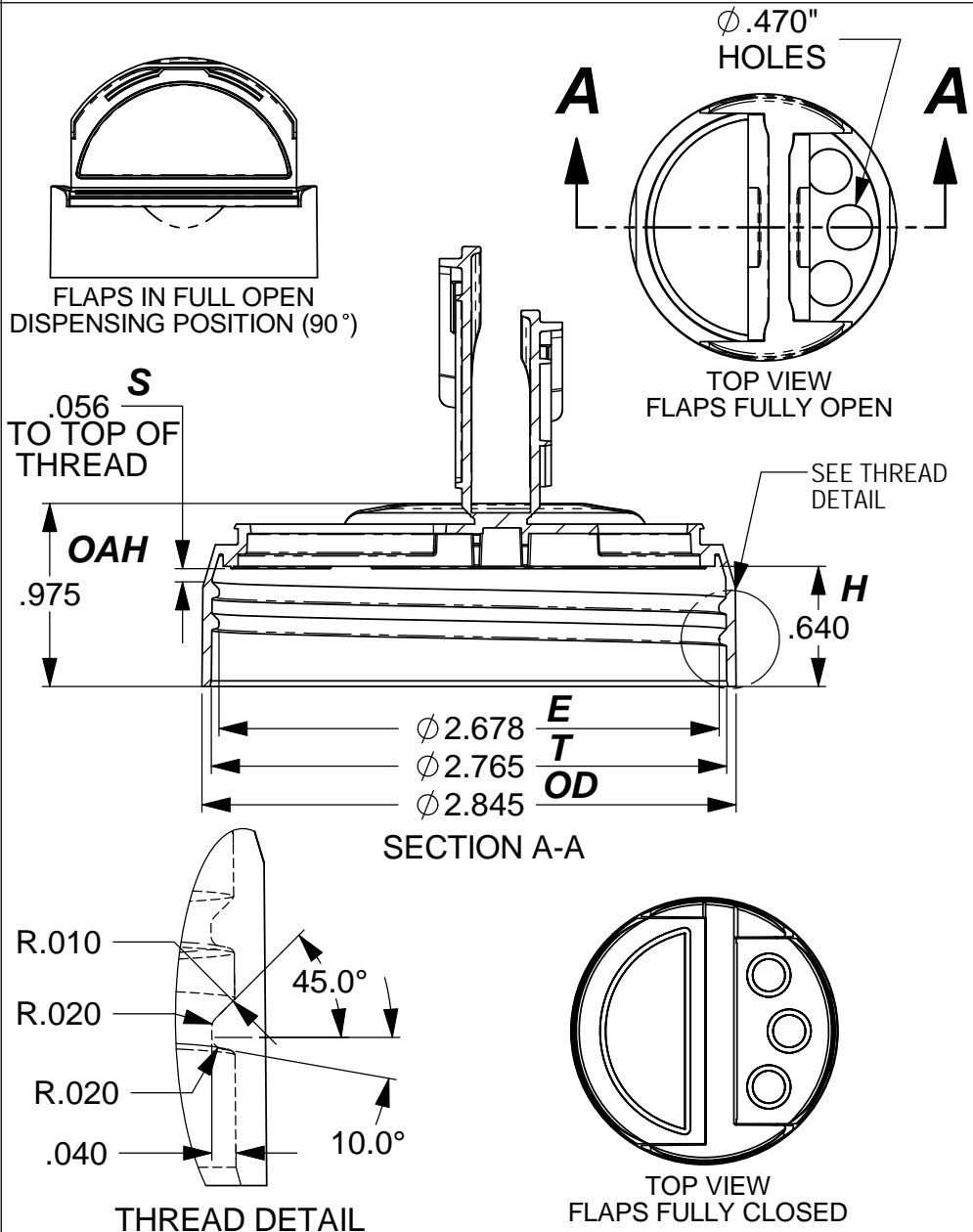

1.5 FULL RH THREADS, 6 TPI

**THEORETICAL PART WEIGHT: 14.52g**  
**OPENING FORCE: 1.5-7.0 LBS**

This drawing is protected by copyright and contains information proprietary to WEATHERCHEM CORPORATION. Any reproduction, disclosure, or use of its contents or any part thereof is expressly prohibited except as WEATHERCHEM CORPORATION otherwise may agree in writing.